

NAME

RACE

TRACK

SURFACE ASPHALT CARPET

COMMENTS

MOTOR

ESC

CELLS

COMMENTS

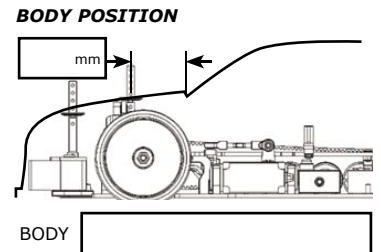

FRONT

SERVO SAVER

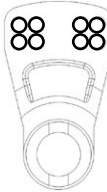

SHOCK ABSORBERS

Holes

Oil

Spring

FRONT AXLE

Ball Diff

LOOSE TIGHT

Solid Axle

One Way

CAMBER

L

R

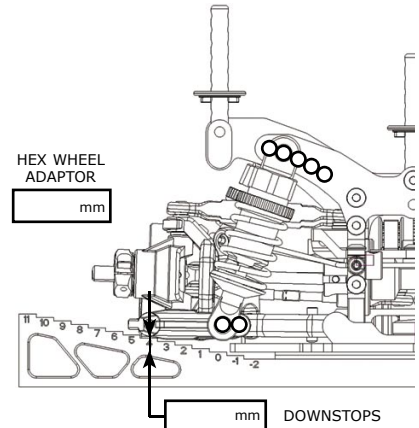
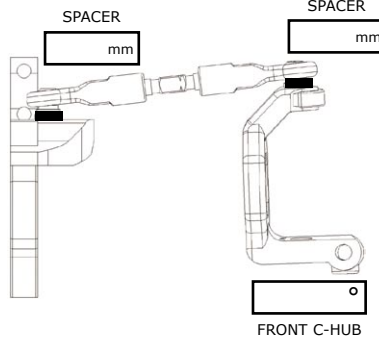
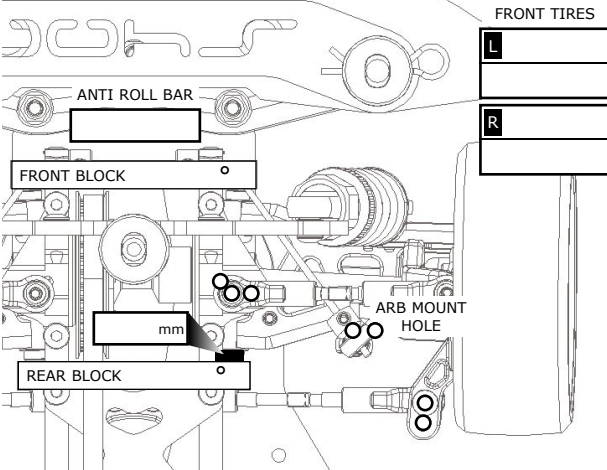
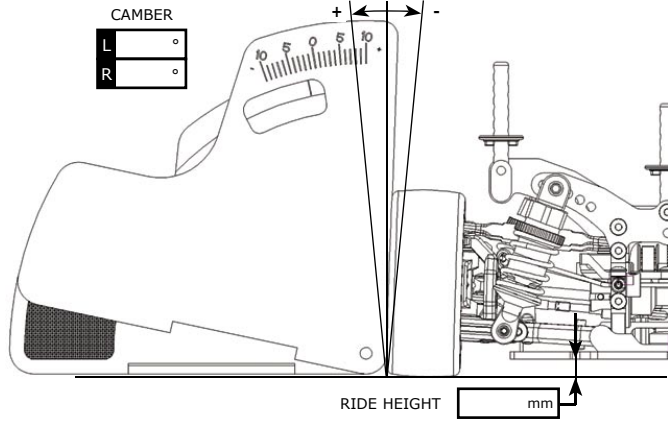

REAR

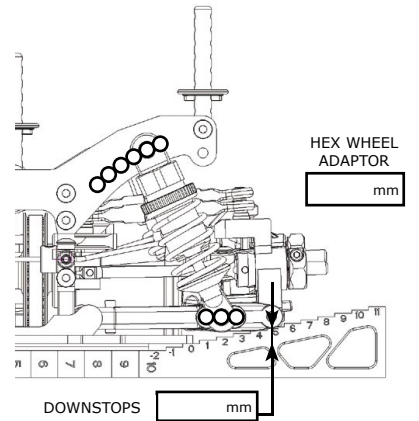
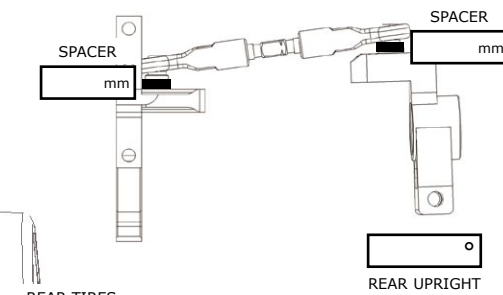
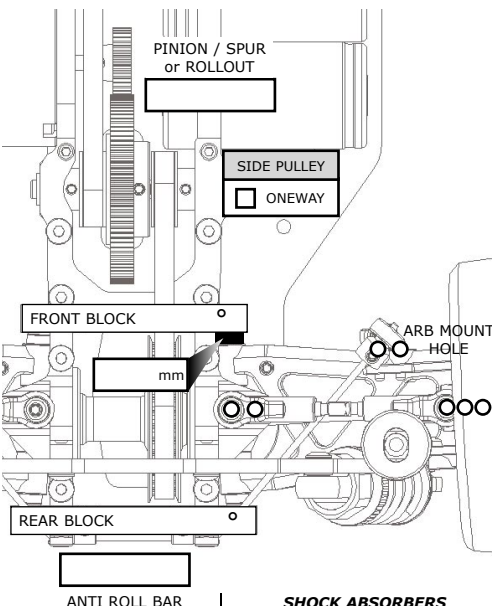

REAR TIRES

L

R

SHOCK ABSORBERS

Holes

Oil

Spring

REAR AXLE

Ball Diff

LOOSE TIGHT

Solid Axle

Gear Diff cst

CAMBER

L

R

